

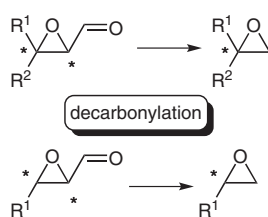

- 2076 B. Morandi  
E. M. Carreira\*

### Catalytic Decarbonylation of Epoxyaldehydes: Applications to the Preparation of Terminal Epoxides



- 2079 G. Savitha  
K. Felix  
P. T. Perumal\*

### Synthesis of Novel 3-Bromo-2*H*-chromene Derivatives: Palladium-Mediated Intramolecular Cyclization of Aryl Propargyl Ethers

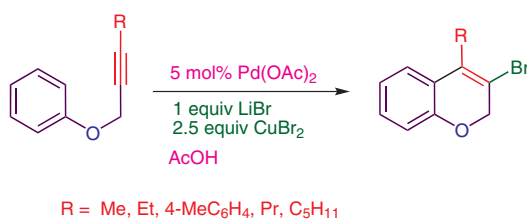

- 2083 K. C. Majumdar\*  
R. N. De  
B. Chattopadhyay  
B. Roy

### Synthesis of Heterocycle-Annulated Medium-Sized Oxacycles and Lactone Derivative by Intramolecular Heck Reaction

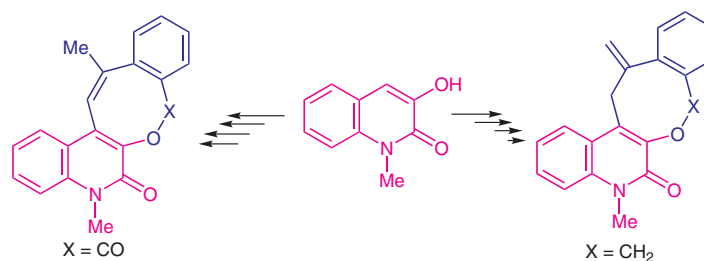

- 2089 J. Saadi  
H.-U. Reissig\*

### Scope and Limitations of Samarium Diodide Induced Cyclizations of Alkenyl-Substituted $\gamma$ -Keto Esters to Benzannulated Cyclooctanol Derivatives

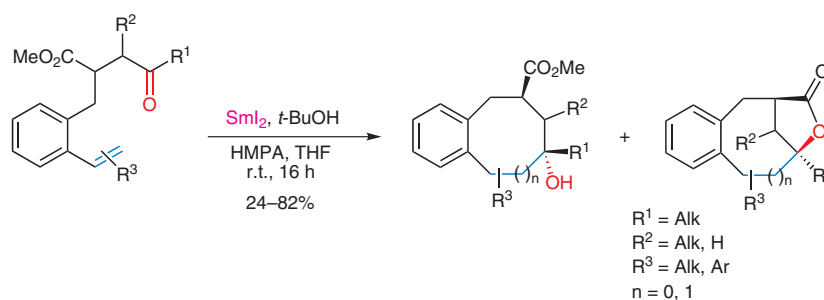

- 2093** D. Castagnolo  
M. Pagano  
M. Bernardini  
M. Botta\*
- Domino Alkylation–Cyclization Reaction of Propargyl Bromides with Thioureas/Thiopyrimidinones: A New Facile Synthesis of 2-Aminothiazoles and 5*H*-Thiazolo[3,2-*a*]pyrimidin-5-ones**

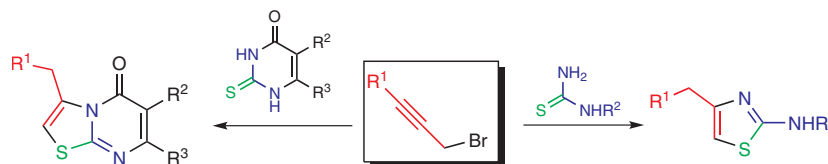

- 2097** N. S. Freeman  
C. Gilon\*
- The Use of Tin(IV) Chloride for Mild and Selective Boc Deprotection on TFA Cleavable Rink-Amide MBHA Resin**

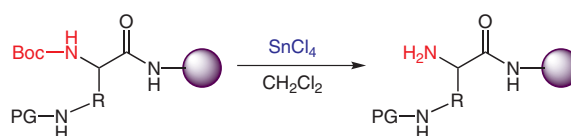

: Rink-amide MBHA resin

PG = Fmoc, Z, Alloc, Dde

- 2101** D. S. Kim  
D. Natalia  
D. Q. Nguyen  
D. J. Suh  
H. Kim  
H. S. Kim\*  
H. Lee\*
- Facile One-Pot Synthesis of 1-Alkyl-3-polyfluoroalkyl Imidazolium Ionic Liquids**

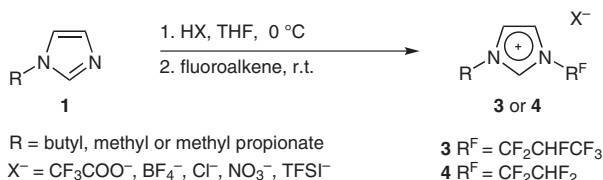

- 2105** N. Sakai\*  
T. Maruyama  
T. Konakahara
- Chemoselective Isomerization of Secondary-Type Propargylic Alcohols to Propargylic/Allenic Bromides, and Brominated Dienes with Appel-Type Reaction Conditions**

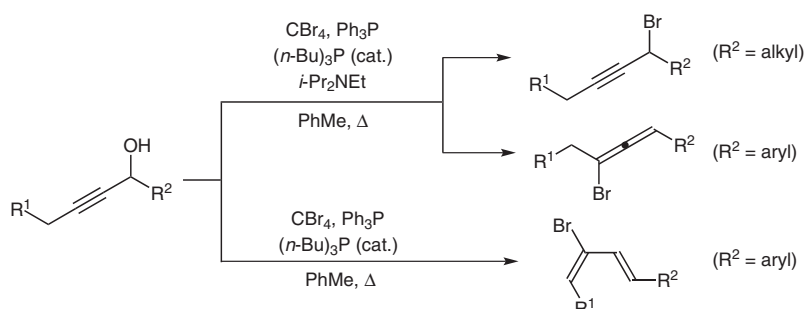

- 2109** X. Guo  
Y. Yue  
G. Hu  
J. Zhou  
Y. Zhao  
L. Yang  
W. Hu\*

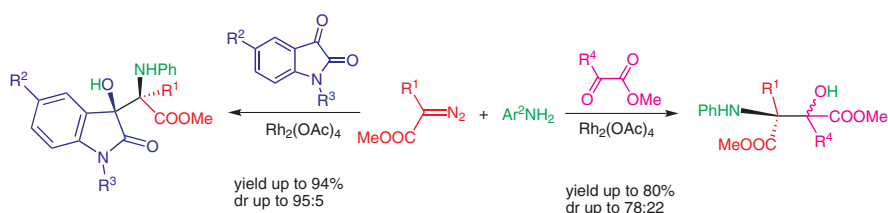

- 2115** T. Tian  
B.-J. Pei  
Q.-H. Li  
H. He  
L.-Y. Chen  
X. Zhou  
W.-H. Chan  
A. W. M. Lee\*

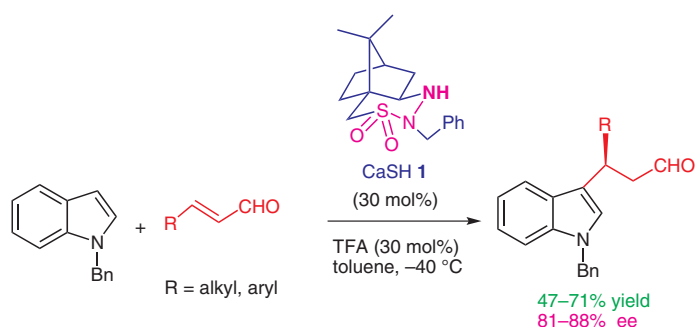

- 2119** A. A. Esmacili\*  
M. Nazer
- One-Pot, Three-Component Chemoselective Reaction of Isoquinolines, Dialkyl Acetylenedicarboxylates, and  $\alpha$ -Ketolactones: An Unexpected Participation of an Ester Carbonyl Group in the 1,4-Dipolar Cycloaddition Reaction**

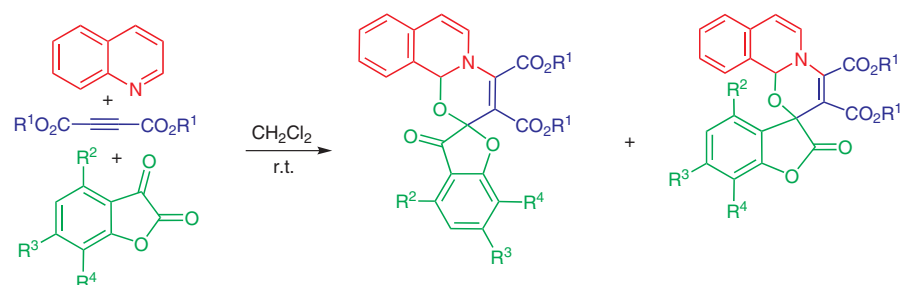

- 2123** V. Malnuit  
M. Duca  
A. Manout  
K. Bougrin  
R. Benhida\*
- Tandem Azide–Alkyne 1,3-Dipolar Cycloaddition/Electrophilic Addition: A Concise Three-Component Route to 4,5-Disubstituted Triazolyl-Nucleosides**

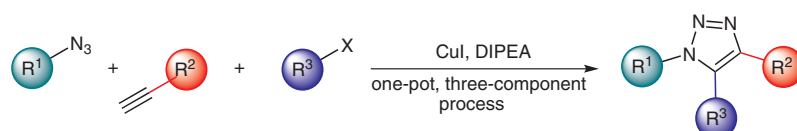

2129 D. K. Mohapatra\*  
U. Dash  
P. R. Naidu  
J. S. Yadav\*

### Stereoselective Total Synthesis of Stagonolide C and Formal Total Synthesis of Modiolide A

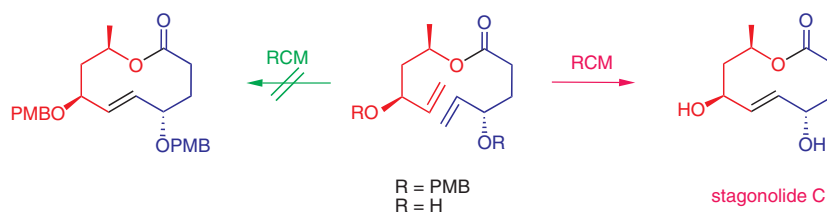

2133 N. Stiasni  
M. Hiersemann\*

### A Stereodivergent Enantioselective Approach to the C5–C8 Segment of Berkelic Acid

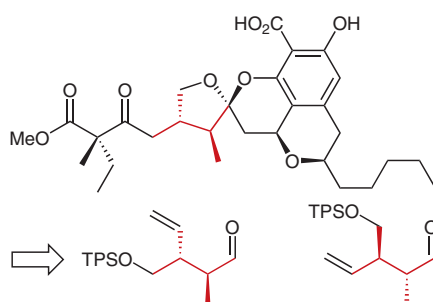

2137 L. Pellegatti  
E. Vedrenne  
J.-M. Leger  
C. Jarry  
S. Routier\*

### First Efficient Palladium-Catalyzed Aminations of Pyrimidines, 1,2,4-Triazines and Tetrazines by Original Methyl Sulfur Release

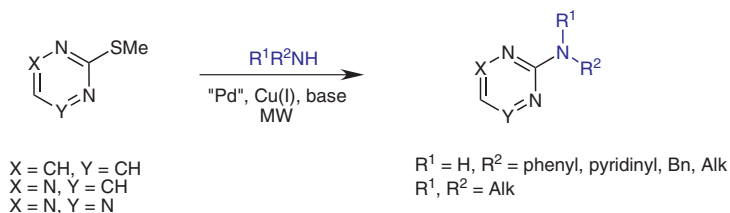

2143 J.-M. Vatèle

### Copper-Catalyzed Aerobic Oxidative Rearrangement of Tertiary Allylic Alcohols Mediated by TEMPO

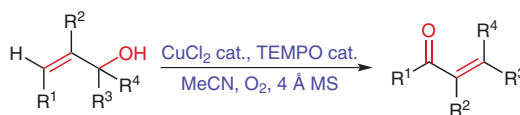

- 2146 A. Alizadeh\*  
N. Zohreh
- A Novel Multicomponent Method for the Synthesis of 2-Thioxo-1,3-thiazolidin-4-ones**

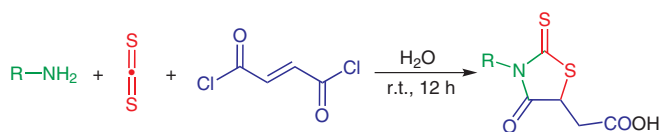

- 2149 A. Porcheddu\*  
L. De Luca  
G. Giacomelli
- A Straightforward Route to Piloty's Acid Derivatives: A Class of Potential Nitroxyl-Generating Prodrugs**

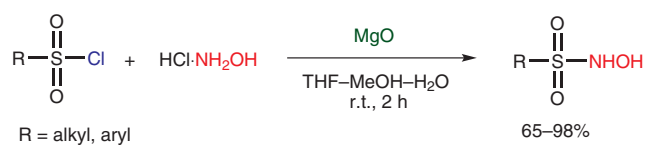

- 2154 M. Nawaz  
M. Adeel  
M. F. Ibad  
P. Langer\*
- Synthesis of Functionalized 2',4-Diarylbenzophenones Based on Site-Selective Suzuki Cross-Coupling Reactions**

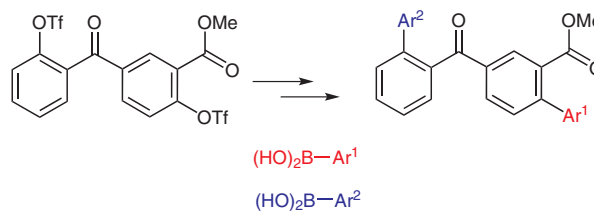

- 2157 A. Cochi  
B. Burger  
C. Navarro  
D. Gomez Pardo\*  
J. Cossy\*  
Y. Zhao  
T. Cohen
- Enantioselective Ring Expansion of Prolinols: An Efficient and Short Synthesis of 2-Phenylpiperidin-3-ol Derivatives and 3-Hydroxypipercolic Acids**

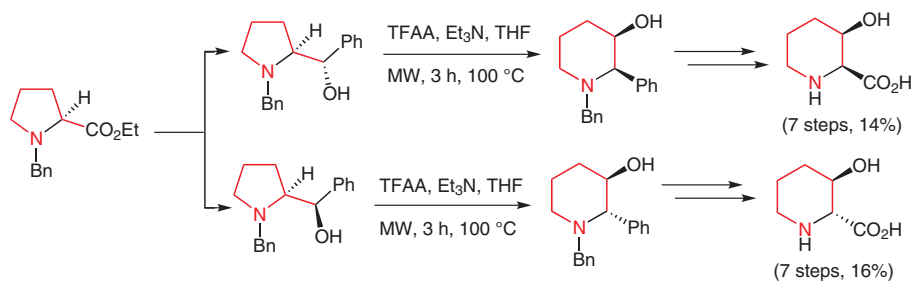

2162 K. P. Kaliappan\*  
P. Kalanidhi  
S. Mahapatra

### 'Click' Chemistry on Sugar-Derived Alkynes: A Tandem 'Click-Click' Approach to Bistriazoles

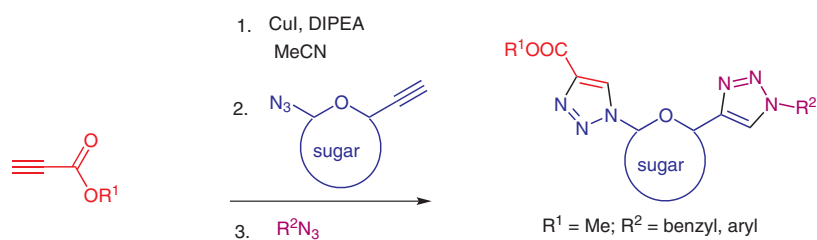

2167 C. Mersch  
S. Wagner  
A. Hoffmann-Röder\*

### Synthesis of Fluorinated Analogues of Tumor-Associated Carbohydrate and Glycopeptide Antigens

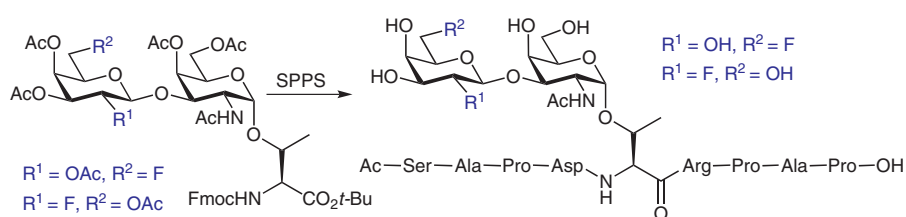

2172 M. Pattarozzi\*  
F. Ghelfi  
F. Roncaglia  
U. M. Pagnoni  
A. F. Parsons

### Synthesis of the Disubstituted Maleic Anhydride Frame Using a Novel Tandem Radical-Polar Reaction

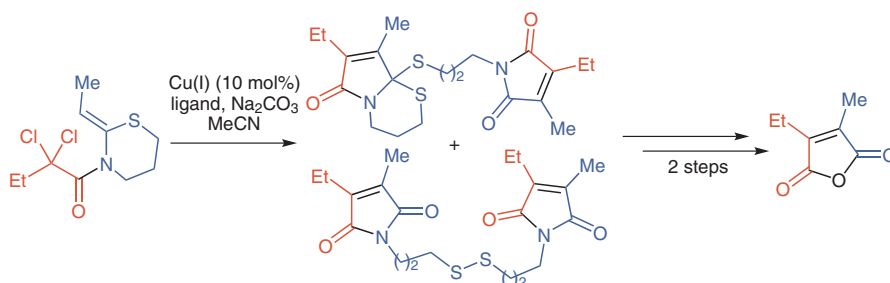

2177 M. Iwasaki  
H. Yorimitsu\*  
K. Oshima\*

### Synthesis of (2-Arylethylidene)cyclobutanes by Palladium-Catalyzed Reactions of Aryl Halides with Homoallyl Alcohols Bearing a Trimethylene Group at the Allylic Position

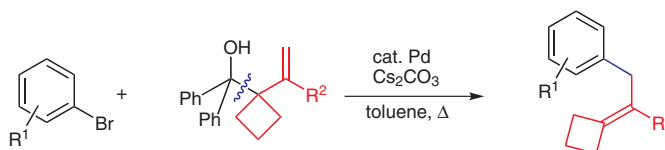

**2180** D. Wu  
Y. He  
R. Tang  
Z. Guan\*

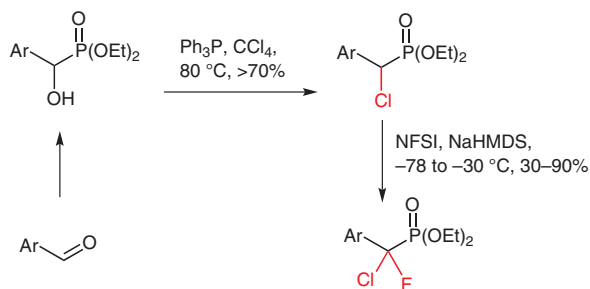
**The First Synthesis of Diethyl  $\alpha,\alpha$ -Chlorofluorobenzylphosphonates**

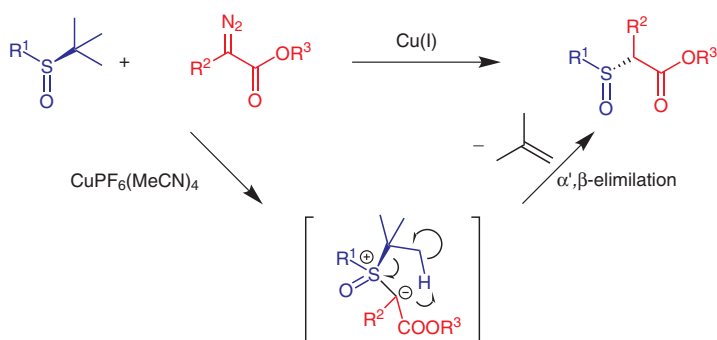
**2183** X.-Y. Guan  
Z.-Q. Liu  
H.-X. Huang  
L.-P. Yang  
L. Jian\*  
W.-H. Hu\*

**Novel C–S Bond Formation Through a  $\alpha,\beta$ -Elimination of *tert*-Butyl Sulfoxonium Ylides: A Facile Approach to Chiral Sulfoxides**

**2188** P. Gao  
Z. Tong  
H. Hu  
P.-F. Xu  
W. Liu  
C. Sun  
H. Zhai\*

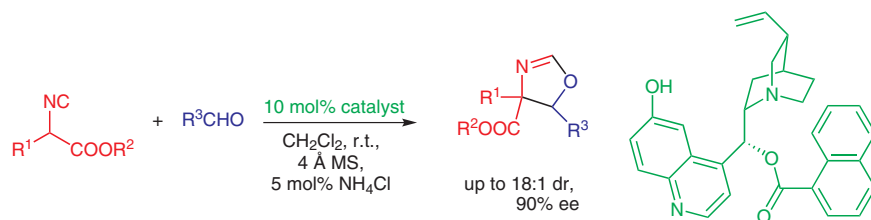
**Synthesis of (+)-9a-*epi*-Stemoamide via DBU-Catalyzed Michael Addition of Nitroalkane**

**2191** M.-X. Xue  
C. Guo  
L.-Z. Gong\*

**Asymmetric Synthesis of Chiral Oxazolines by Organocatalytic Cyclization of  $\alpha$ -Aryl Isocyanooesters with Aldehydes**

2198 Z. Ye  
F. Chen  
F. Luo  
W. Wang  
B. Lin  
X. Jia  
J. Cheng\*

**Palladium-Catalyzed Mizoroki–Heck-Type Reaction of Aryl Trimethoxysilanes**

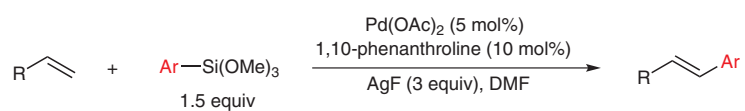

2201 Compiled by  
H. Yao

**Dimethylsulfonium Methylide: A Versatile Reagent**

2203 Compiled by  
A. Goswami

**DABAL-Me<sub>3</sub>: A Versatile Methylating Agent**

XVII

**Forthcoming Articles**

*Letters*

*Spotlights*

## Author Index

---

- Adeel, M. 2154  
 Alizadeh, A. 2146  
  
 Bernardini, M. 2093  
 Benhida, R. 2123  
 Bezzenine-Lafollée, S. 2051  
 Botta, M. 2093  
 Bougrin, K. 2123  
 Burger, B. 2157  
  
 Carreira, E. M. 2076  
 Castagnolo, D. 2093  
 Chan, W.-H. 2115  
 Chattopadhyay, B. 2083  
 Chen, F. 2198  
 Chen, L.-Y. 2115  
 Cheng, J. 2198  
 Cochi, A. 2157  
 Cohen, T. 2157  
 Collin, J. 2051  
 Cossy, J. 2157  
  
 Dash, U. 2129  
 De Luca, L. 2149  
 De, R. N. 2083  
 Duca, M. 2123  
  
 Esmacili, A. A. 2119  
  
 Felix, K. 2079  
 Freeman, N. S. 2097  
  
 Gao, P. 2188  
 Ghelfi, F. 2172  
 Giacomelli, G. 2149  
 Gil, R. 2051  
 Gilon, C. 2097  
 Gomez Pardo, D. 2157  
 Gong, L.-Z. 2191  
  
 Goswami, A. 2203  
 Guan, X.-Y. 2183  
 Guan, Z. 2180  
 Guo, C. 2191  
 Guo, X. 2109  
  
 He, H. 2115  
 He, Y. 2180  
 Hiersemann, M. 2133  
 Hoffmann-Röder, A. 2167  
 Hu, G. 2109  
 Hu, H. 2188  
 Hu, W. 2109  
 Hu, W.-H. 2183  
 Huang, H.-X. 2183  
  
 Ibad, M. F. 2154  
 Iwasaki, M. 2177  
  
 Jaber, N. 2051  
 Jarry, C. 2137  
 Jia, X. 2198  
 Jian, L. 2183  
  
 Kalanidhi, P. 2162  
 Kaliappan, K. P. 2162  
 Kendall, J. 2068  
 Kim, D. S. 2101  
 Kim, H. 2101  
 Kim, H. S. 2101  
 Konakahara, T. 2105  
  
 Langer, P. 2154  
 Lee, A. W. M. 2115  
 Lee, H. 2101  
 Leger, J.-M. 2137  
 Li, Q.-H. 2115  
 Lin, B. 2198  
 Liu, W. 2188  
  
 Liu, Z.-Q. 2183  
 Luo, F. 2198  
  
 Mahapatra, S. 2162  
 Majumdar, K. C. 2083  
 Malnuit, V. 2123  
 Manout, A. 2123  
 Martin, M. 2051  
 Maruyama, T. 2105  
 McDonald, R. 2068  
 Mersch, C. 2167  
 Miyaura, N. 2039  
 Mohapatra, D. K. 2129  
 Morandi, B. 2076  
  
 Naidu, P. R. 2129  
 Natalia, D. 2101  
 Navarro, C. 2157  
 Nawaz, M. 2154  
 Nazer, M. 2119  
 Nguyen, D. Q. 2101  
  
 Oshima, K. 2177  
  
 Pagano, M. 2093  
 Pagnoni, U. M. 2172  
 Parsons, A. F. 2172  
 Pattarozzi, M. 2172  
 Pei, B.-J. 2115  
 Pellegatti, L. 2137  
 Perumal, P. T. 2079  
 Porcheddu, A. 2149  
  
 Reboule, I. 2051  
 Reissig, H.-U. 2089  
 Roncaglia, F. 2172  
 Routier, S. 2137  
 Roy, B. 2083  
  
 Saadi, J. 2089  
 Sakai, N. 2105  
 Savitha, G. 2079  
 Stiasni, N. 2133  
 Suh, D. J. 2101  
 Sun, C. 2188  
  
 Tang, R. 2180  
 Tian, T. 2115  
 Tong, Z. 2188  
 Tykwinski, R. R. 2068  
  
 Vatèle, J.-M. 2143  
 Vedrenne, E. 2137  
  
 Wagner, S. 2167  
 Wang, W. 2198  
 Wu, D. 2180  
  
 Xu, P.-F. 2188  
 Xue, M.-X. 2191  
  
 Yadav, J. S. 2129  
 Yang, L. 2109  
 Yang, L.-P. 2183  
 Yao, H. 2201  
 Ye, Z. 2198  
 Yorimitsu, H. 2177  
 Yue, Y. 2109  
  
 Zhai, H. 2188  
 Zhao, Y. 2109  
 Zhao, Y. 2157  
 Zhou, J. 2109  
 Zhou, X. 2115  
 Zohreh, N. 2146